

VISORES / REPETIDORES

Indicators / Remotes - Indicateurs / Répétiteurs



Generales / Generals - Généraux

Repetidores inteligentes con más de 60 protocolos de entrada y de salida:

Remote repeaters with more than 60 IN/OUT protocols:

Répétiteurs intelligents avec plus de 60 protocoles d'entrée et de sortie:

- **Conectividad RS232, RS485 y vía radio**

RS232, RS485 and wireless connectivity
Connectivité RS232, RS485 et via radio

- **Posibilidad de displays de grandes dimensiones con LEDs de alta luminosidad (variable)**

Ultra bright variable luminosity LEDs large displays possibility
Possibilité de displays de grandes dimensions avec des LEDs de haute luminosité

- **Dispone de teclas para realizar taras, zeros y acumulaciones remotas**

Remote tare, zero and accumulate key functions available
Il dispose de touches pour la réalisation de taras, zéros et accumulations éloignées.

- **Dispone de todas las funcionalidades de un visor (relés, salidas 4-20mA, 0-10V, etc.) en las versiones CRT**

Indicator's functionalities are available (relays, 4-20mA outputs, 0-10V outputs, etc.)
Il a toutes les fonctions propres d'un indicateur (relais, sorties 4-20mA, 0-10V, etc.)

- **Protocolo CUSTOM que permite repetir cualquier trama en ASCII que este enviando un visor de forma continua**

CUSTOM protocol that allows repeating any frame in ASCII that an indicator is sending continuously

Protocole CUSTOM qui permet de répéter n'importe quelle trame en ASCII qu'un indicateur envoie en continu

19 mm

SCA1-P/LCD
SCA1-P/LED
SCA1-I/LCD
SCA1-I/LED
SCA1-CRT-P/LCD
SCA1-CRT-P/LED
SCA1-CRT-I/LCD
SCA1-CRT-I/LED



40 mm

SCA40
SCA40R

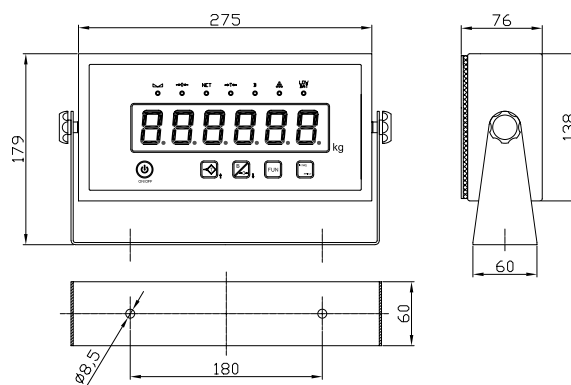

100 mm

SCA100-W/IP
SCA100R-W/IP
SCA100-W-CRT/IP

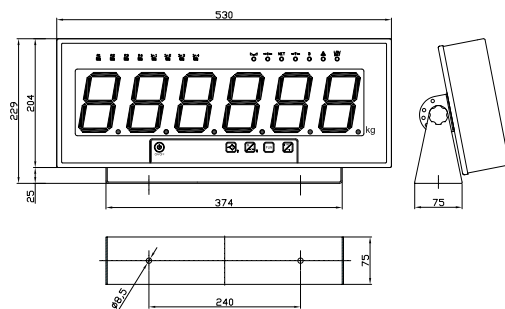

Visera opcional

Protection visor optional

Visière de protection optionnel

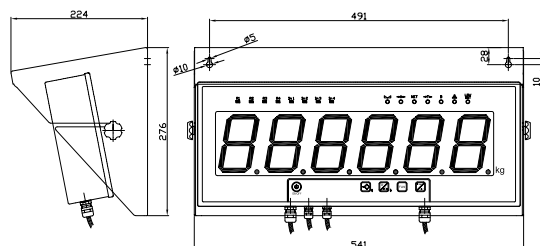

60 mm

SCA60-W
SCA60-W/IP
SCA60R-W/IP
SCA60-W-CRT/IP
SCA60R-W-CRT/IP

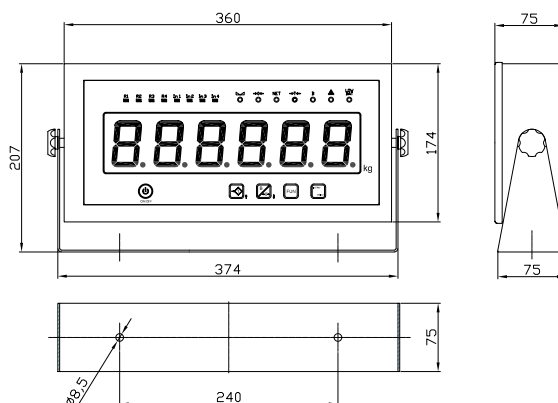

VISORES / REPETIDORES

Indicators / Remotes - Indicateurs / Répétiteurs



	Digit Size	Type Digit	Indicator	Remote	Connectors / IP	Additional Cartridges
SCA1-P/LCD	19 mm	LCD	✓	✓	Connectors / IP	
SCA1-P/LED	19 mm	Red LED	✓	✓	Connectors / IP	
SCA1-I/LCD	19 mm	LCD	✓	✓	Connectors / IP	
SCA1-I/LED	19 mm	Red LED	✓	✓	Connectors / IP	
SCA1-CRT-P/LCD	19 mm	LCD	✓	✓	Connectors	✓
SCA1-CRT-P/LED	19 mm	Red LED	✓	✓	Connectors	✓
SCA1-CRT-I/LCD	19 mm	LCD	✓	✓	Connectors	✓
SCA1-CRT-I/LED	19 mm	Red LED	✓	✓	Connectors	✓
SCA40	40 mm	Red LED	✓		Connectors	
SCA40R	40 mm	Red LED		✓	Connectors	
SCA60-W	60 mm	White LED	✓		Connectors	
SCA60-W/IP	60 mm	White LED	✓		IP	
SCA60R-W/IP	60 mm	White LED		✓	IP	
SCA60-W-CRT/IP	60 mm	White LED	✓		IP	✓
SCA60R-W-CRT/IP	60 mm	White LED		✓	IP	✓
SCA100-W/IP	100 mm	White LED	✓		IP	
SCA100R-W/IP	100 mm	White LED		✓	IP	
SCA100-W-CRT/IP	100 mm	White LED	✓		IP	✓

Múltiples posibilidades de conexión: Visor-Repetidor, Visor-PC, Redes de comunicación a través de los puertos disponibles o los cartuchos adicionales

Multiple connection possibilities: Indicator-Repeater, Indicator-PC, Communication networks through the available ports or additional cartridges

Multiples possibilités de connexion : Indicateur-Répéteur, Indicateur-PC, Réseaux de communication via les ports disponibles ou des cartouches supplémentaires



Communication RS232



Communication RS485



Via Radio 868 MHz connection